

COMPONENTS • MANUFACTURING
ONE Trusted SOURCE
ASSEMBLY • TESTING

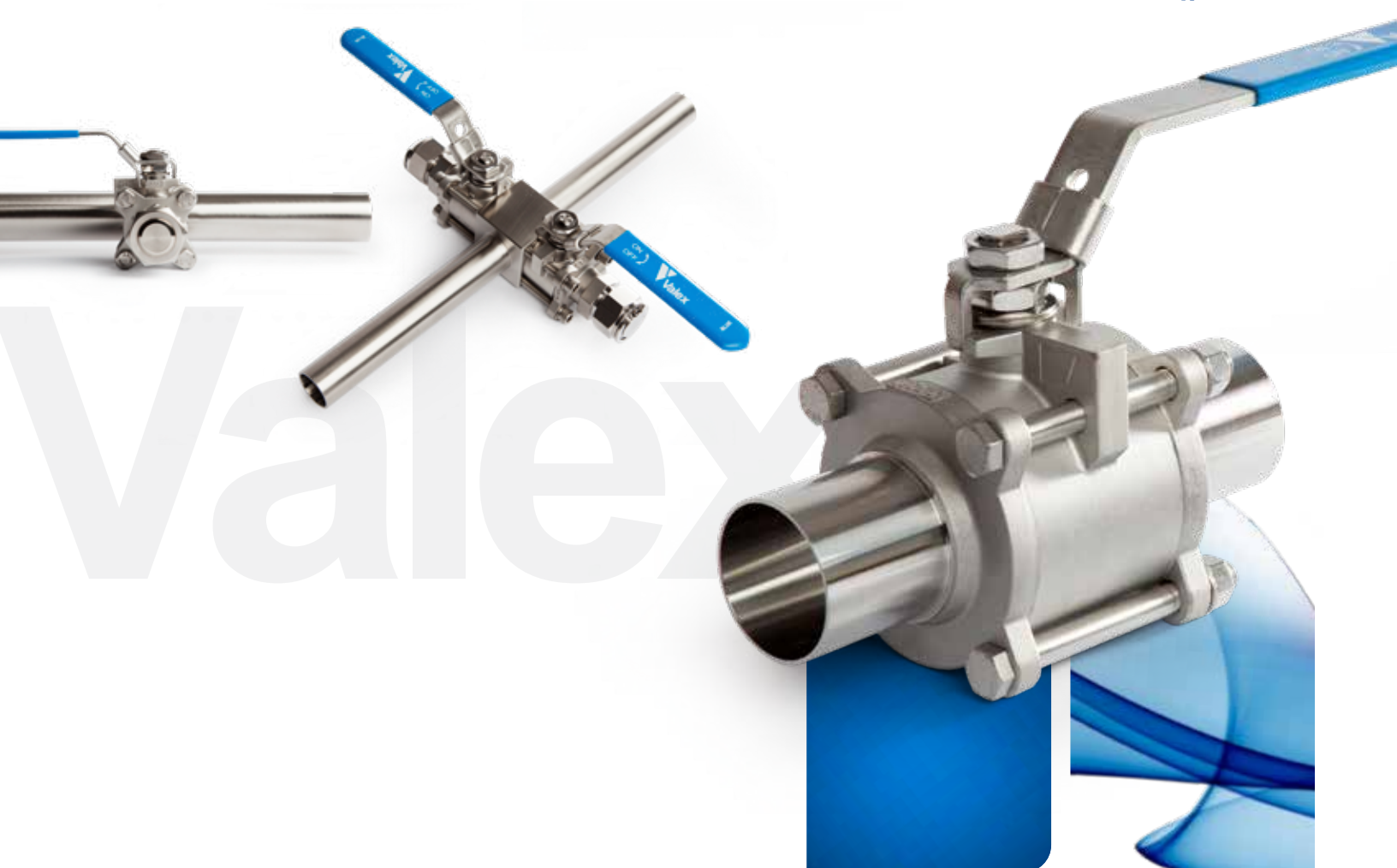

High-Purity
Ball Valves



High-Purity Ball Valves

CFOS Applications

- Cost-effective systems where cleaning for oxygen-grade services are required, such as: Clean-Dry Air (CDA), Oil-Free Air (OFA), General Nitrogen (GN2), Utility Nitrogen (UN2), and other inert gas applications.

Product Description

- Size Range:
 - Tube: 1/4" o.d. to 6" o.d.
 - JIS Pipe: 15A to 250A
 - NPS Pipe: NPS 1/2 to NPS 14
- Temperature Range:
 - 20°F to 350°F (-29°C to 177°C)
- Stainless steel construction
- Wide variety of end connections available

Features & Benefits

- High flow full-port design
- Available in various integrated tee valve assemblies using Valex tube and tube fittings
- High cycle-life performance
- Floating ball for positive shut-off
- 3-Piece construction for ease of maintenance
- Color-coded handle options
- Locking handle for lock-out/tag-out applications
- Each valve includes a Certificate-of-Compliance to Valex specification SP-9217
- 100% Helium leak tested
- Nitrogen-purged and double polyethylene bagged
- Cleaned for Oxygen Service (CFOS)
- ISO Class 5 cleanroom assembled, tested & packaged
- PED Certification available





Flow Coefficient

ASTM Tube Sizes

Valve Size	Ball Orifice	Cv ¹
1/4" x .035"	0.402"	2.9
3/8" x .035"	0.402"	9.0
1/2" x .049"	0.402"	16.2
3/4" x .065"	0.620"	41.1
1" x .065"	0.870"	85.7
1-1/2" x .065"	1.370"	223
2" x .065"	1.870"	432
2-1/2" x .065"	2.370"	713
3" x .065"	2.870"	1,069
4" x .083"	3.834"	1,971
6" x .109"	5.782"	4,688

NPS Pipe Sizes (Schedule 10)

Valve Size	Ball Orifice	Cv ¹
NPS 1/2	0.591"	37.0
NPS 3/4	0.787"	68.5
NPS 1	0.984"	110
NPS 1-1/4	1.260"	186
NPS 1-1/2	1.496"	269
NPS 2	1.969"	481
NPS 2-1/2	2.559"	839
NPS 3	3.150"	1,301
NPS 4	3.937"	2,085
NPS 5	4.921"	3,338
NPS 6	5.906"	4,902
NPS 8	7.874"	8,980
NPS 10	9.843"	14,354
NPS 12	11.811"	21,048
NPS 14	13.268"	26,864

JIS Pipe Sizes (Schedule 10)

Valve Size	Ball Orifice	Cv ¹
JIS 15A	0.591"	37.0
JIS 20A	0.787"	68.5
JIS 25A	0.984"	110
JIS 32A	1.260"	186
JIS 40A	1.496"	269
JIS 50A	1.969"	481
JIS 65A	2.559"	839
JIS 80A	3.150"	1,301
JIS 100A	3.937"	2,085
JIS 125A	4.921"	3,338
JIS 150A	5.906"	4,902
JIS 200A	7.874"	8,980
JIS 250A	9.843"	14,354



Pressure Temperature Rating

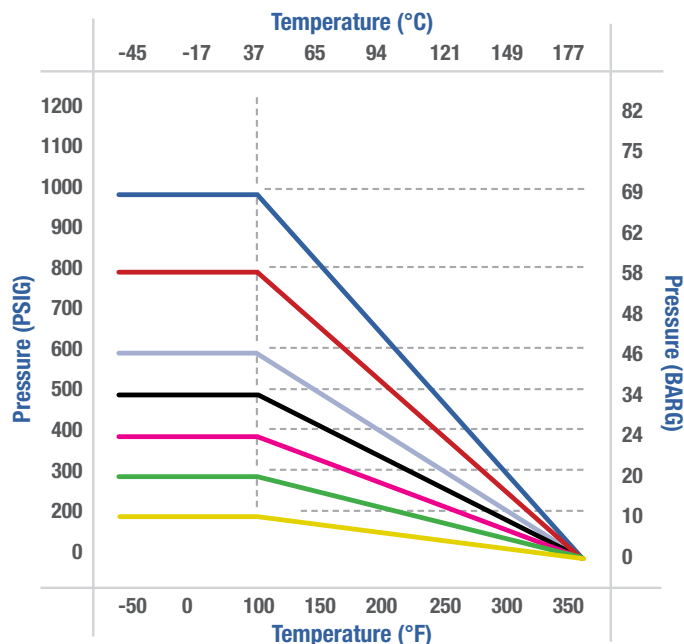

ASTM Tube Sizes

- 1/4" - 1" Tube
- 1.5" - 2" Tube
- 2.5" - 4" Tube
- 6" Tube

NPS Pipe Sizes (Sch 10)

- NPS 1/2 - NPS 1-1/2
- NPS 2
- NPS 3
- NPS 4 - NPS 5
- NPS 6 - NPS 10
- NPS 12 - NPS 14

JIS Pipe Sizes (Sch 10)

- 15A - 40A
- 50A
- 80A
- 100A - 125A
- 150A - 250A
- 300A - 350A

1. Flow coefficient data calculated using methods described in Crane Technical Paper TP-410.



HP Ball Valve

Tube x Tube
Pipe x Pipe

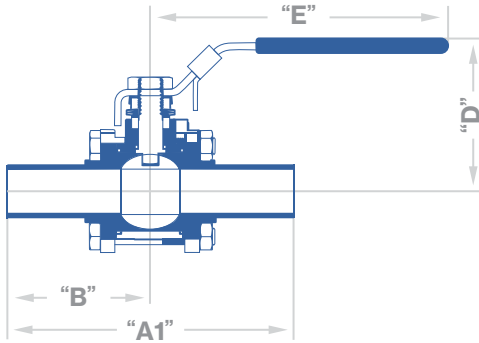

Tube x Compression

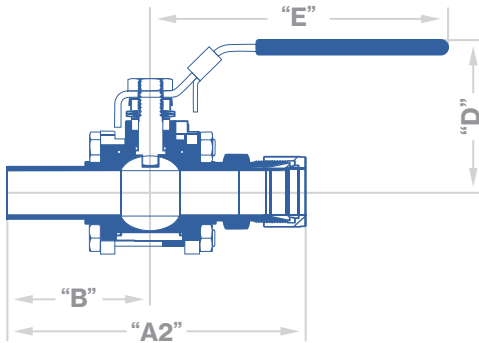

Compression x Compression

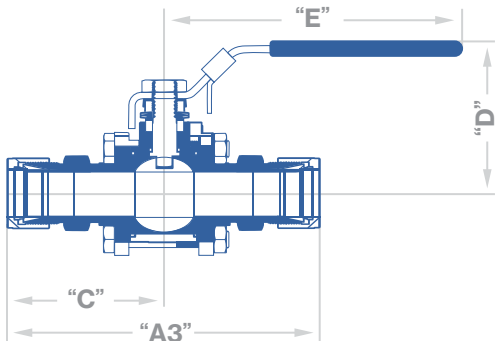

ASTM Tube Sizes

Dimensions Below in Inches

Size	"A1"	"A2"	"A3"	"B"	"C"	"D"	"E"
1/4"	4.50"	4.09"	3.68"	2.25"	1.84"	2.16"	4.40"
3/8"	4.50"	4.18"	3.82"	2.25"	1.91"	2.16"	4.40"
1/2"	5.00"	4.56"	4.13"	2.50"	2.06"	2.16"	4.40"
3/4"	5.25"	5.01"	4.77"	2.63"	2.39"	2.32"	5.11"
1"	5.50"	5.77"	6.04"	2.75"	3.02"	2.92"	5.65"
1-1/2"	7.00"	7.80"	8.59"	3.50"	4.30"	3.76"	7.72"
2"	8.00"			4.00"		4.12"	7.72"
2-1/2"	9.50"			4.75"		5.68"	12.08"
3"	10.80"			5.40"		6.03"	12.08"
4"	12.35"			6.18"		7.04"	15.52"
6"	17.00"			8.50"		10.6"	18" - 36"

NPS Pipe Sizes (Schedule 10)

Dimensions Below in Millimeters

Size	"A1"	"B"	"D"	"E"
NPS 1/2	135.4	67.7	59	105
NPS 3/4	135	67.5	65	133
NPS 1	152	76	74	159
NPS 1-1/4	157	78.5	78	159
NPS 1-1/2	190	95	91	198
NPS 2	204	102	99	198
NPS 2-1/2	254	127	137	260
NPS 3	280	140	149	260
NPS 4	306	153	186	288
NPS 5	320	160	198	325-650
NPS 6	376.4	188.2		
NPS 8	457	228.5		
NPS 10	533	266.5		
NPS 12	610	305		

JIS Pipe Sizes (Schedule 10)

Dimensions Below in Millimeters

Size	"A1"	"B"	"D"	"E"
JIS 15A	135.4	67.7	59	105
JIS 20A	135	67.5	65	133
JIS 25A	152	76	74	159
JIS 32A	157	78.5	78	159
JIS 40A	190	95	91	198
JIS 50A	204	102	99	198
JIS 65A	254	127	137	260
JIS 80A	280	140	149	260
JIS 100A	306	153	186	288
JIS 125A	320	160	198	325 - 650
JIS 150A	376.4	188.2		
JIS 200A	457	228.5		
JIS 250A	533	266.5		
JIS 300A	610	305		

Dimensions are approximate, subject to change, and may vary from valve to valve.
Please check the Valex website for latest dimensions.



Materials of Construction

Item	Qty	Part	Material
A	2	SPRING WASHERS	300 SERIES SS
B	1	BODY	CF8M SS
C	1	NUT STOP	304 SS
D	1	HANDLE NUT	300 SERIES SS
E	1	STEM NUT	300 SERIES SS
F	1	HANDLE	300 SERIES SS
G	1	HANDLE COVER	VINYL POLYMER
H	2	GLAND WASHERS	300 SERIES SS
I	1	STEM PACKING	PTFE
J	1	THRUST WASHER	PTFE
K	1	STEM	316 SS
L	2	SEAT	PTFE/RPTFE
M	2	BODY GASKET	PTFE
N	4	END CAP FLANGE HARDWARE	300 SERIES SS
O	2	END CAP FLANGE	CF3M SS
P	1	BALL	316L/CF3M SS

SS = Stainless Steel

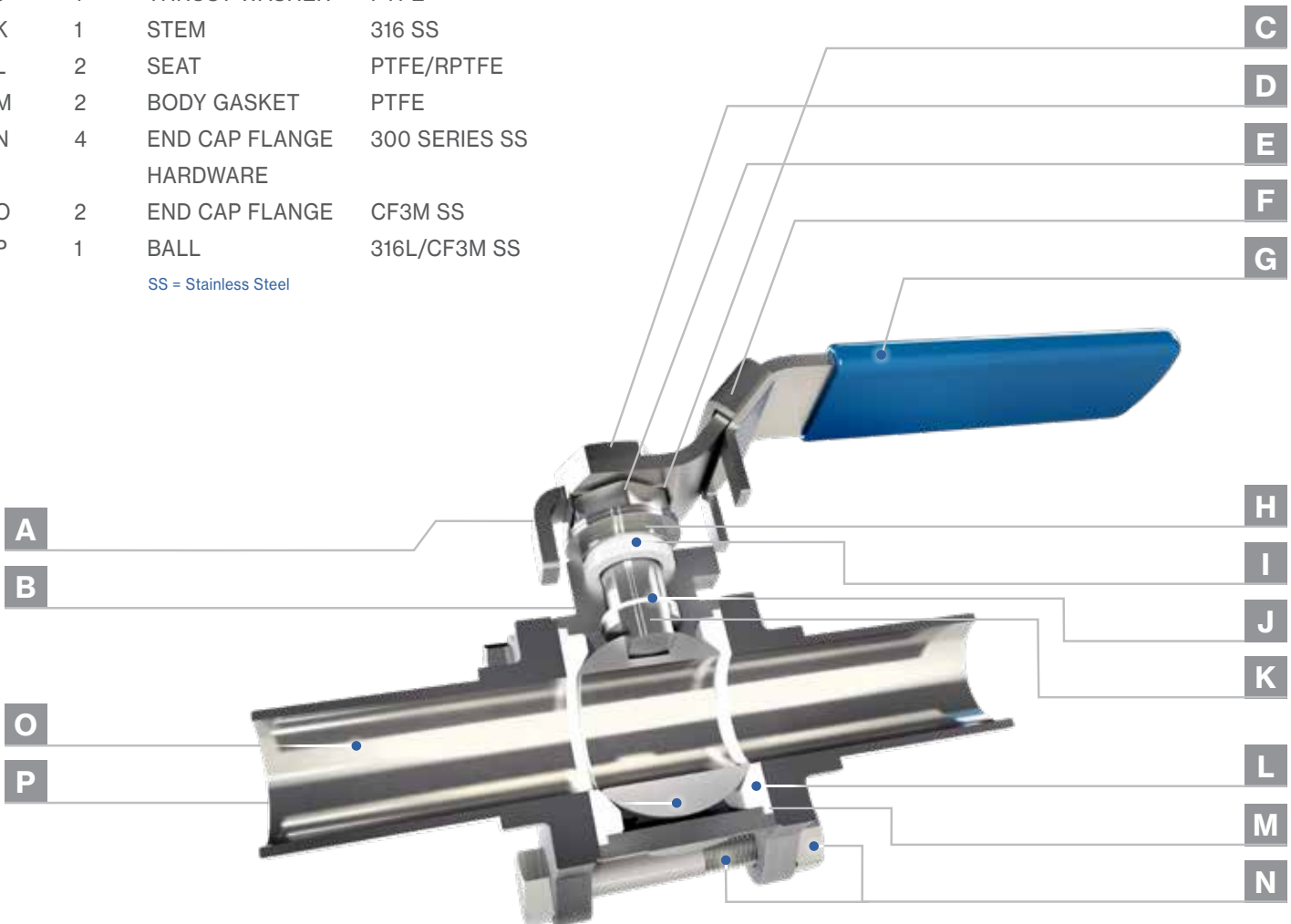



Handles

- Standard locking lever:
Tube 1/4" – 4"
JIS 15A – 100A
NPS 1/2 – NPS 4
- Tee style bar handle:
Tube 6"
JIS 125A
NPS 5
- Gearbox actuation:
JIS 150A – 250A
NPS 6 – NPS 14

Handle Color Options

Blue handles come standard, or choose from nine different color-coded handles for easy process line identification. Colors include: blue, red, pink, white, brown, yellow, green, black, purple, silver, and gold.

Custom Spools & Manifold Assemblies

Valex can build specialty CFOS valve assemblies that reduce field welds and installation time.

From integrated tee valve sub-assemblies, all the way to 24-foot long CFOS manifolds, each assembly is custom built out of Vallex tube, pipe, fittings and valves. Our mission of providing products and services that meet or exceed our customers expectations. Vallex is your one trusted source for all of your CFOS needs. Contact your local Vallex representative for more details.





Standard Configurations

Straight Valve



Single Horizontal Cross



Double Horizontal Cross



Double Single Sided



Double Vertical Tee



Double Horizontal Tee



Rebuild Kits

Complete PTFE/RPTFE seal and hardware kits are available to service all Valex high-purity valves. Rebuild kits include new stem packing seals, body gasket seals, thrust washer, and ball seats. Also included, is a full stainless steel hardware kit to keep your high-purity valve operating like new.

Ordering Information

Example:

S - S T R 4 0 A - X X X S S - M B

S

Material

S = Stainless Steel

S | T | R

Assembly Pattern

STR = Straight
DHC = Double Horizontal Cross
SHC = Single Horizontal Cross
DHT = Double Horizontal Cross

DVT = Double Vertical Tee
DAV = Double Angle Valve
DSS = Double Single Sided

4 | 0

Main Tube / Pipe Sizes

04 = 1/4" o.d. x .035" Wall	15 = DN15 (NPS 1/2 / JIS 15A)
06 = 3/8" o.d. x .035" Wall	20 = DN20 (NPS 3/4 / JIS 20A)
08 = 1/2" o.d. x .049" Wall	25 = DN25 (NPS 1 / JIS 25A)
12 = 3/4" o.d. x .065" Wall	32 = DN32 (NPS 1-1/4 / JIS 32A)
16 = 1" o.d. x .065" Wall	40 = DN40 (NPS 1-1/2 / JIS 40A)
24 = 1-1/2" o.d. x .065" Wall	50 = DN50 (NPS 2 / JIS 50A)
32 = 2" o.d. x .065" Wall	65 = DN65 (NPS 2-1/2 / JIS 65A)
40 = 2-1/2" o.d. x .065" Wall	80 = DN80 (NPS 3 / JIS 80A)
48 = 3" o.d. x .065" Wall	100 = DN100 (NPS 4 / JIS 100A)
64 = 4" o.d. x .083" Wall	150 = DN150 (NPS 6 / JIS 150A)
96 = 6" o.d. x .109" Wall	200 = DN200 (NPS 8 / JIS 200A)
	250 = DN250 (NPS 10 / JIS 250A)
	300 = DN300 (NPS 12 / JIS 300A)
	350 = DN350 (NPS 14 / JIS 350A)

A

Main Tube / Pipe Connections

A = JIS (Sch 5) Pipe Butt weld Inlet/Outlet
B = Tube Butt weld Inlet, Tube Butt weld Outlet w/ Welded Cap
C = Compression Fitting Inlet & Outlet
D = JIS (Sch 10) Pipe Butt weld Inlet/Outlet
E = Tube Butt weld Inlet, FNPT Outlet
F = Face-seal Fixed Male Inlet & Outlet
G = Tube Butt weld Inlet, Face-seal Fixed Male Outlet
H = Compression Fitting Inlet, Tube Butt weld Outlet
J = Tube Butt weld Inlet, Compression Fitting Outlet
K = Face-seal Fixed Male Inlet, Tube Butt weld Outlet
L = NPS (Sch 10) Pipe Butt weld Inlet/Outlet
M = Tube Butt weld Inlet & Outlet
N = Tube Butt weld Inlet, B16.5 Class 150 Flange Outlet
P = B16.5 Class 150 Flange Inlet & Outlet
Q = Compression Fitting w/ Plug Inlet, Tube Butt weld Outlet
R = Tube Butt weld Inlet, Compression Fitting w/ Plug Outlet

X | X

Branch Valve(s) Outlet Size

04 = 1/4" o.d. x .035" Wall	XX = No Branch Valve(s)
06 = 3/8" o.d. x .035" Wall	15 = DN15 (NPS 1/2 / JIS 15A)
08 = 1/2" o.d. x .049" Wall	20 = DN20 (NPS 3/4 / JIS 20A)
12 = 3/4" o.d. x .065" Wall	25 = DN25 (NPS 1 / JIS 25A)
16 = 1" o.d. x .065" Wall	32 = DN32 (NPS 1-1/4 / JIS 32A)
24 = 1-1/2" o.d. x .065" Wall	40 = DN40 (NPS 1-1/2 / JIS 40A)
32 = 2" o.d. x .065" Wall	50 = DN50 (NPS 2 / JIS 50A)
40 = 2-1/2" o.d. x .065" Wall	65 = DN65 (NPS 2-1/2 / JIS 65A)
48 = 3" o.d. x .065" Wall	80 = DN80 (NPS 3 / JIS 80A)
64 = 4" o.d. x .083" Wall	100 = DN100 (NPS 4 / JIS 100A)
96 = 6" o.d. x .109" Wall	150 = DN150 (NPS 6 / JIS 150A)

X

Connection On Branch Valve(s)

X = No Branch Valve(s)
A = JIS (Sch 5) Pipe Butt weld
B = Tube Butt weld w/ Welded Cap
C = Compression Fitting
D = NPS (Sch 10) w/ B16.5 Class 150 Flange
E = Female NPT National Pipe Thread
F = Face-seal Fixed Male
L = NPS (Sch 10) Pipe Butt weld
M = Tube Butt weld
P = Compression Fitting w/ Plug

S

Inlet Purge Port*

X = No Purge Port
C = Compression Fitting
D = Purge Drill (Open to Atmosphere)
P = Compression Fitting w/ Plug
S = Face-Seal (Swivel Male Nut w/ Cap)
T = Purge Tube (Open to Atmosphere)
U = Face-Seal (Swivel Female Nut w/ Plug)
V = Purge Valve w/ Compression Fitting

S

Outlet Purge Port*

X = No Purge Port
C = Compression Fitting
D = Purge Drill (Open to Atmosphere)
P = Compression Fitting w/ Plug
S = Face-Seal (Swivel Male Nut w/ Cap)
T = Purge Tube (Open to Atmosphere)
U = Face-Seal (Swivel Female Nut w/ Plug)
V = Purge Valve w/ Compression Fitting

M

Section 9.0 Identifier

E = 10 Ra Electropolished
L = 10 Ra Electropolished, Oxygen-Compatible Lube
M = Standard Finish Option (per SP-9217)

B

Handle Sleeve Color

0 = N/A	N = Brown
B = Blue	P = Purple
D = Gold	R = Red
G = Green	S = Silver
I = Pink	W = White
K = Black	Y = Yellow

Not all possible part number combinations are available.
Please contact Valex for availability.

* Purge Port Sizes:
1/4" purge port is used for valve sizes up to 2" Tube & DN50 Pipe (NPS 2 / JIS 50A)
1/2" purge port is used for valve sizes larger than 2" Tube & DN50 Pipe (NPS 2 / JIS 50A)



Neither ozone-depleting nor mercury-bearing compounds are used during Valex processing or testing of any product.



Benefit From World Leadership

We are your trusted source for high-purity ball valves, PCW ball valves, instrumentation ball valves, headers, manifolds, pipe, tube, fittings and more. For more information, please visit our website or contact your Valex representative. Benefit from world leadership, and benefit from Valex quality.



Valex Corporate Offices & Manufacturing

**Valex USA
Corporate Headquarters**

6080 Leland Street
Ventura, CA 93003
United States of America
Phone: 805-658-0944



**Valex USA
Round Rock, TX**

120 E. Old Settlers Blvd.
Round Rock, TX 78664
United States of America
Phone: 512-212-8100



**Valex USA
Georgetown, TX**

1805 Titan Dr.
Georgetown, Texas 78628
United States of America
Phone: 737-340-4600



Valex Korea

32 Hansan-gil, Cheongbuk-eup
Pyeongtaek-si, Gyeonggi-do
Republic of Korea
Phone: 82-31-683-0119



Valex China

358 Zhonggang Road
Haiyan Economic Dev. Zone,
Jiaxing, Zhejiang 314305
People's Republic of China
Phone: 86-573-86868221

