

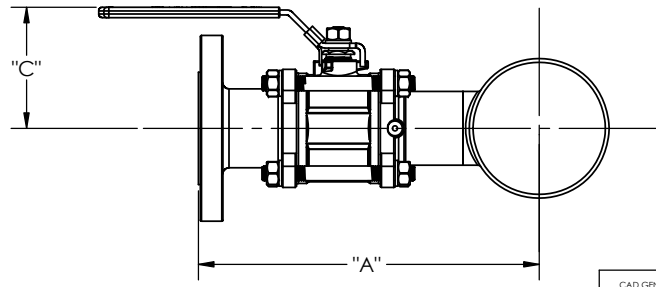

REVISION RECORD			
REV.	DATE	DESCRIPTION	DCN
F	09-10-2020	CHANGES PER DCN 4871	4871

DIMENSIONS IN MILLIMETERS						
SIZE		"A"	"B"	"C"	"D"	"E"
MAIN	BRANCH					
NPS 2	NPS 3/4	158.2	228.6	65	233	228.6
NPS 3	NPS 3/4	172.5	304.8	65	247	304.8
NPS 4	NPS 3/4	185.2	304.8	65	260	304.8
NPS 6	NPS 3/4	211.0	304.8	65	286	304.8
NPS 2	NPS 1	174.7	228.6	74	270	228.6
NPS 3	NPS 1	189.0	304.8	74	285	304.8
NPS 4	NPS 1	201.7	304.8	74	297	304.8
NPS 6	NPS 1	227.5	304.8	74	323	304.8
NPS 2	NPS 1.5	229.2	304.8	91	329	304.8
NPS 3	NPS 1.5	243.5	304.8	91	343	304.8
NPS 4	NPS 1.5	256.2	304.8	91	355	304.8
NPS 6	NPS 1.5	282.0	304.8	91	381	304.8
NPS 8	NPS 1.5	307.3	304.8	91	406	304.8
NPS 3	NPS 2	266.0	304.8	99	349	304.8
NPS 4	NPS 2	278.7	304.8	99	362	304.8
NPS 6	NPS 2	304.4	304.8	99	386	304.8
NPS 8	NPS 2	329.8	304.8	99	411	304.8
NPS 4	NPS 3	325.9	304.8	149	462	304.8
NPS 6	NPS 3	351.7	304.8	149	488	304.8
NPS 8	NPS 3	377.0	304.8	149	513	304.8

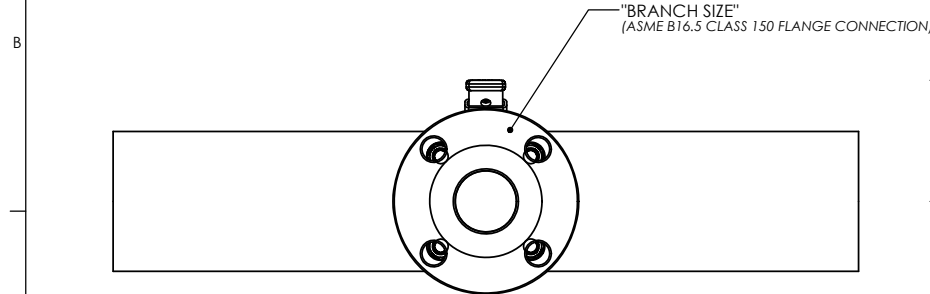
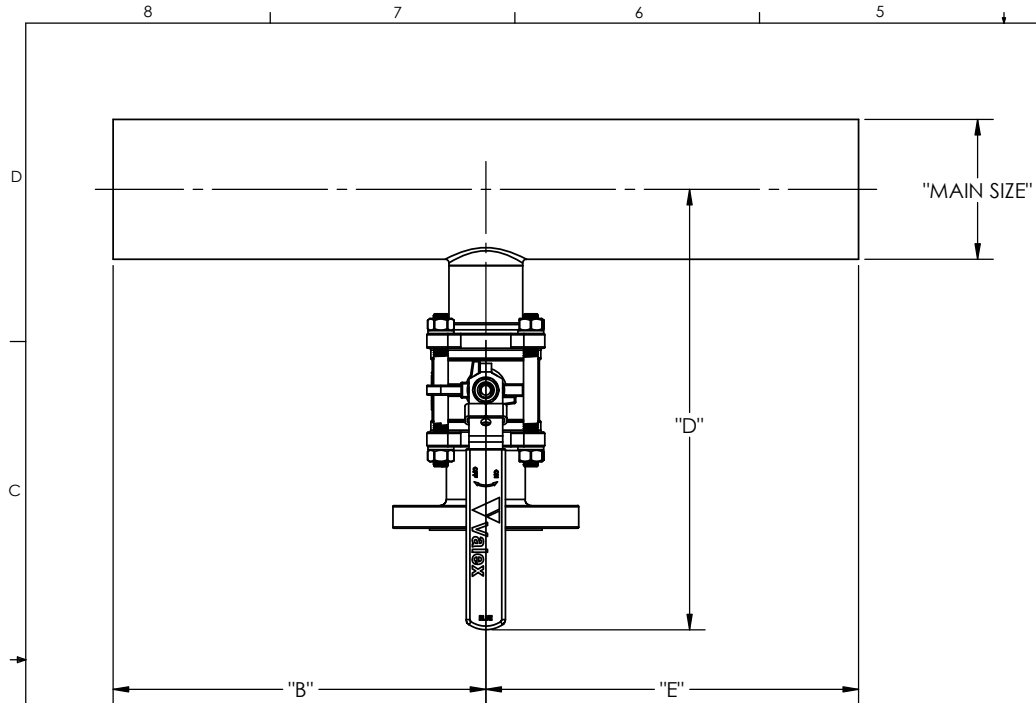

1. DIMENSIONS ARE APPROXIMATE AND MAY VARY FROM VALVE TO VALVE. REFERENCE VALEX SPECIFICATION SP-9236 FOR OVERALL LENGTH TOLERANCES.
2. DIMENSIONS ARE SUBJECT TO CHANGE AS PRODUCT IMPROVEMENTS MAY ALTER VALVE DESIGN.

NOTES: UNLESS OTHERWISE SPECIFIED

CAD GENERATED DRAWING. DO NOT MANUALLY UPDATE		 6080 LELAND ST. VENTURA, CA, 93003 (805) 638-0944 www.valex.com	
APPROVALS	DATE	BALL VALVE, PCW SHC CROSS, PIPE X FLANGE	DWG. NO. PDC-PCW-SHC-LF REV. F
DRAWN C. MAO	06-24-2013		
CHECKED T. NEVINS	06-25-2013	SCALE: 1:4 SHEET 1 OF 1	
ENG. C. MAO	06-25-2013		
Q.A. R. MULDRONG	06-25-2013		
MFG. T. KELLENBERGER	06-25-2013		